

- 3) Install the injection pump rear bracket ④ and the rear bracket bolts ⑤ to the cylinder body.
- 4) Install the rear bracket bolts ⑥ to the injection pump bracket.
Do not tighten the bolts.
The rear bracket bolts ⑤ and ⑥ will be finally tightened to the specified torque after the injection pump nuts.
- 5) Tighten the injection pump nuts to the specified torque.

Injection Pump Nut and Bracket Bolt Torque

Torque	kg·m(lb.ft/N·m)
	1.5 ± 0.5 ($10.8 \pm 3.6/14.70 \pm 4.90$)

050506010701

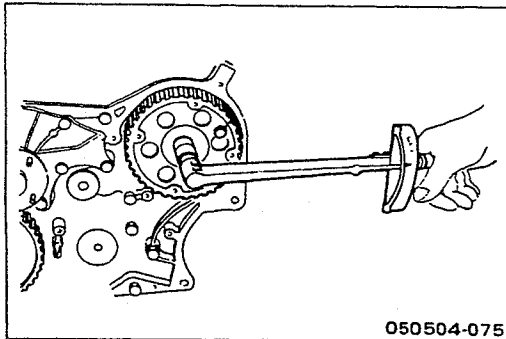

▲ Injection Pump Timing Pulley (For Belt Drive)

- 1) Align the timing pulley with the pump shaft key.
- 2) Install the stopper bolt to the timing pulley.
This will prevent the timing pulley from turning.
- 3) Tighten the timing pulley nut to the specified torque.

Injection Pump Timing Pulley Nut Torque	kg·m(lb.ft/N·m)
	6.5 ± 0.5 ($47.0 \pm 3.6/63.77 \pm 4.90$)

- 4) Remove the stopper bolt from the injection pulley.

0505060113

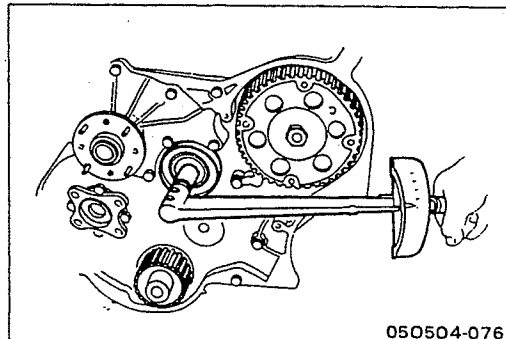

▲ Tension Idler (For Belt Drive)

- 1) Install the tensioner idler to the timing belt.
- 2) Tighten the tensioner idler to the specified torque.

Tensioner Idler Bolt Torque	kg·m(lb.ft/N·m)
	7.7 ± 1.0 ($55.7 \pm 7.2/75$)

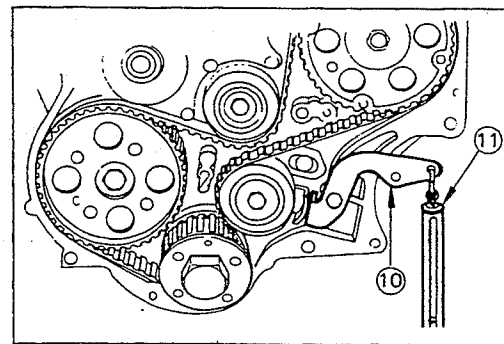
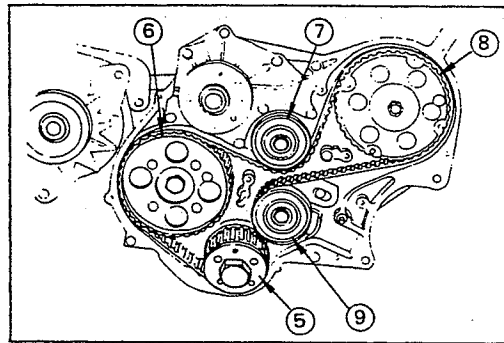
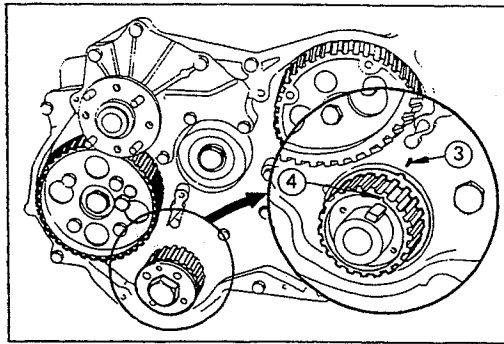
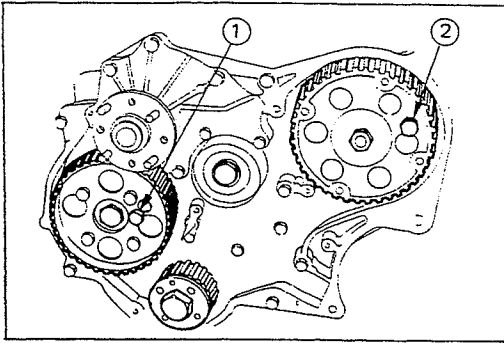

▲ Timing Belt (For Belt Drive)

▲ Timing Belt Tensioner (For Belt Drive)

▲ Timing Belt Tension Adjusting Lever (For Belt Drive)

1) Check that the stopper bolts are properly installed to the camshaft timing pulley ① and the injection pump timing pulley ②.

2) Check that the timing pulley housing mark ③ and the crankshaft timing pulley mark ④ are aligned.
The No. 1 cylinder should be at TDC on the compression stroke.

Rotate the crankshaft damper pulley clockwise to align the marks.

3) Install the timing belt to the crankshaft timing pulley ⑤, the camshaft timing pulley ⑥, the tensioner idler ⑦, and the injection timing pulley ⑧.

Follow the numerical order.

4) Install the timing belt tensioner ⑨ to the timing pulley housing.

5) Temporarily tighten the tensioner bolt.

The tensioner should move freely.

Note:

The timing belt is easily damaged. Be careful.

6) Set the tensioner adjusting lever ⑩ to the timing pulley housing.

7) Remove the stopper bolts from the camshaft timing pulley and the injection pump timing pulley.

8) Attach the spring balancer ⑪.

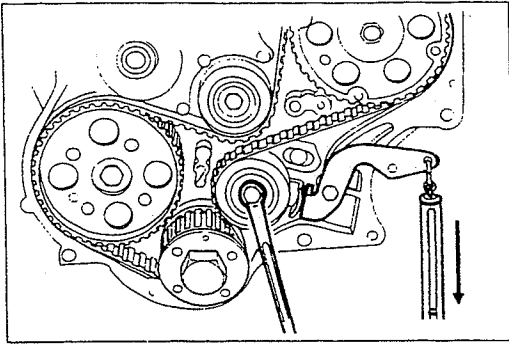

- 9) Adjust the timing belt tension by pulling straight down on the spring balancer with the specified force.

Tension Adjusting Lever Force	kg(lb/N)
10 - 12	(22.1 - 26.5/98.1 - 117.7)

Note:

Timing belt tension must be adjusted.

Failure to adjust the timing belt tension will result in timing belt damage.

- 10) Tighten the tension bolt.

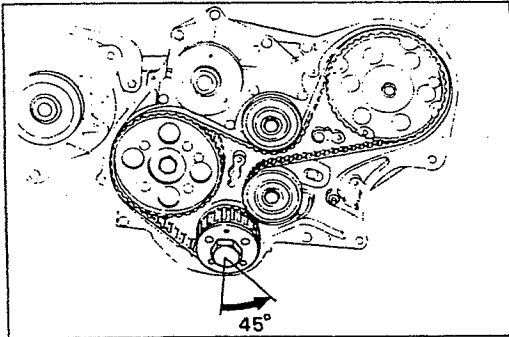

- 11) Rotate the crankshaft 45 degrees counterclockwise.

Note:

Never rotate the crankshaft clockwise when adjusting the timing belt.

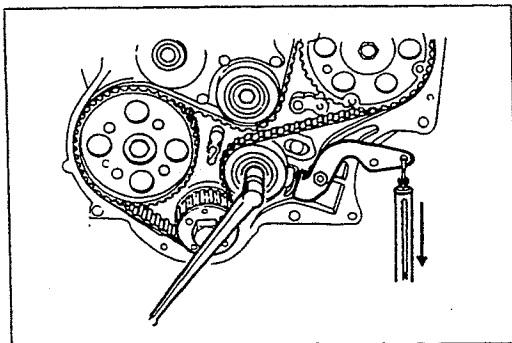

- 12) Readjust the timing belt tension.

Refer to Step 9

This will remove any remaining timing belt slack.

- 13) Tighten the tensioner bolt to the specified torque.

Tensioner Bolt Torque	kg·m(lb.ft/N·m)
7.7 ± 1.0	(55.7 ± 7.2/75.5 ± 9.8)

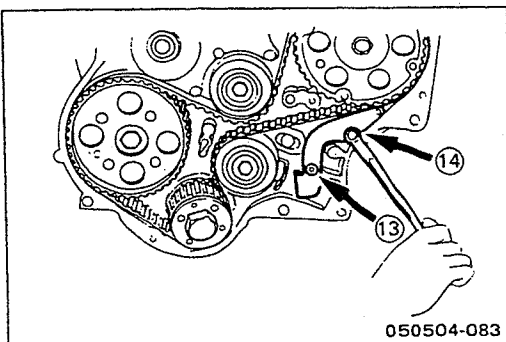

- 14) Tighten the tension adjusting lever nut (13) and bolt (14).

Note:

If on-vehicle timing belt replacement is performed, the crankshaft must not be allowed to turn.

If the crankshaft is allowed to turn, piston and valv damage will result.

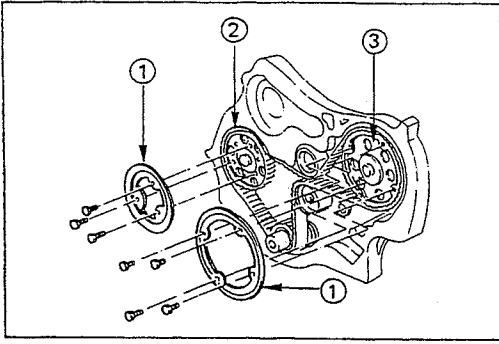

▲ Camshaft Timing Pulley Flange (For Belt Drive)

▲ Injection Pump Timing Pulley Flange (For Belt Drive)

- 1) Install the timing pulley flange ① to the camshaft ② and injection pump timing pulley ③.
- 2) Tighten the timing pulley flange bolts to the specified torque.

Timing Pulley Flange Bolt Torque	kg·m(lb.ft/N·m)
	1.9 ± 0.5 ($13.7 \pm 3.6/18.62 \pm 4.90$)

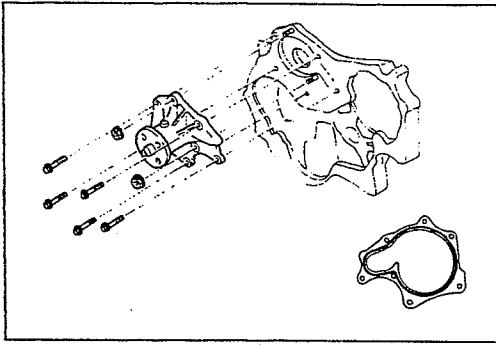

▲ Water Pump

- 1) Apply the recommended liquid gasket or its equivalent to the water pump at the position shown in the illustration.

Do not apply an excessive amount of liquid gasket.

- 2) Tighten the water pump bolts to the specified torque.

Water Pump Bolt Torque	kg·m(lb.ft/N·m)
	2.0 ± 0.5 ($14.5 \pm 3.6/19.60 \pm 4.90$)

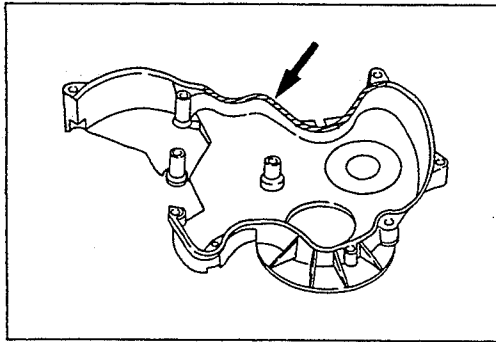

▲ Timing Pulley Housing Lower Cover (For Belt Drive)

▲ Timing Pulley Housing Upper Cover (For Belt Drive)



- 1) Apply the recommended liquid gasket or its equivalent to the timing pulley lower cover.
- 2) Install the lower cover ① to the timing pulley housing ②.

Use the lower cover guide bolts ③ to prevent the liquid gasket from running.

- 3) Install the upper cover ④ to the lower cover and pulley housing.
- 4) Tighten the timing cover bolts to the specified torque a little at a time in the sequence shown in the illustration.

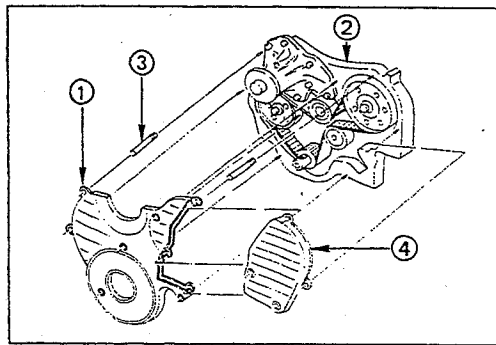

Timing Pulley Cover Bolt Torque	kg·m(lb.ft/N·m)
	0.8 ± 0.2 ($5.8 \pm 1.4/7.84 \pm 1.96$)

- 5) Remove the lower cover guide pin.

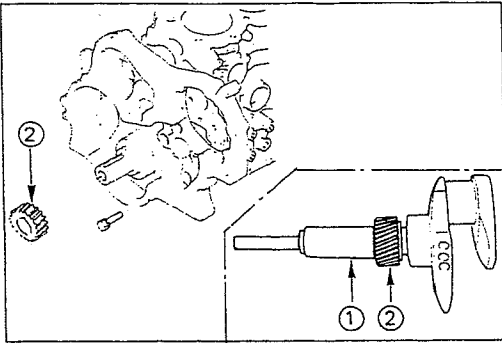

▲ Crankshaft Timing Gear (For Gear Drive)

- 1) Install the crankshaft gear.
- 2) Use the crankshaft gear installer ① to install the crankshaft gear ②.

The crankshaft gear timing mark ("X-X") must be facing outward.

Crankshaft Gear Installer: 9-8522-0020-0

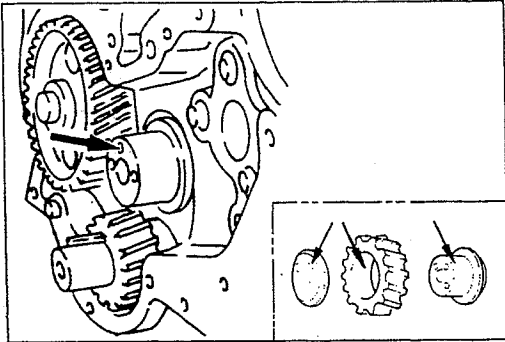

▲ Idler Gear Shaft (For Gear Drive)

▲ Idler Gear "A" (For Gear Drive)

- 1) Apply engine oil to the idler gear and the idler gear shaft.

The idler gear shaft oil hole must be facing up.

- 2) Position the idler gear setting marks "X" and "Y" so that they are facing the front of the engine.

0505040134B

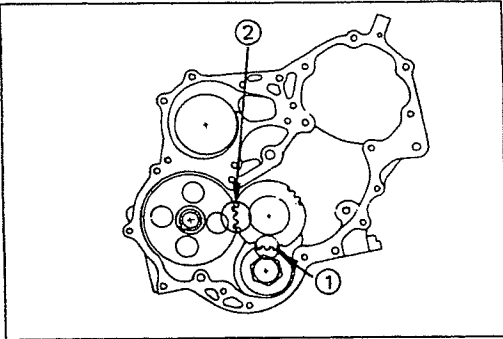

- 3) Align the idler gear "X" setting mark with the crankshaft timing gear ① "X-X" setting mark.

- 4) Align the idler gear "Y" setting mark with the camshaft timing gear ② "Y-Y" setting mark.

- 5) Install the thrust collar and bolts to the cylinder body through the shaft.

The thrust collar oil hole must be facing up, and the thrust collar chamfered must be outward.

- 6) Tighten the idler gear bolt to the specified torque.

Idler Gear "A" Bolt Torque kg-m(lb.ft/N-m)

1.9 ± 0.5 (13.7 ± 3.6/18.62 ± 4.90)

0505040135

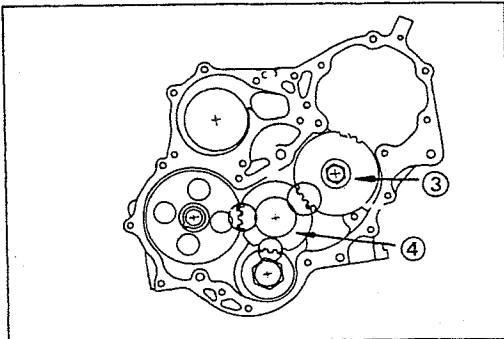

▲ Idler Gear "B" and Shaft (For Gear Drive)

- 1) Apply engine oil to the idler gear and the idler gear shaft.

- 2) Align the idler gear "B" ③ "Z" setting mark with the idler gear "A" ④ "Z-Z" setting mark.

- 3) Tighten the idler gear bolt to the specified torque.

Idler Gear "B" Bolt Torque kg-m(lb.ft/N-m)

7.7 ± 1.0 (55.7 ± 7.2/75.46 ± 9.80)

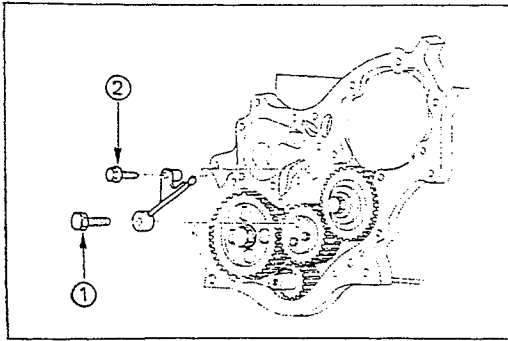

▲ Timing Gear Oil Pipe (For Gear Drive)

- 1) Install the oil pipe to the timing gear case and idler gear "A".
- 2) Tighten the oil pipe eye bolt ① and bolt ② to the specified torque.

Eye Joint and Bolt Torque	kg·m(lb.ft/N·m)
	$1.25 \pm 0.25 (9.0 \pm 1.8/12.25 \pm 2.45)$

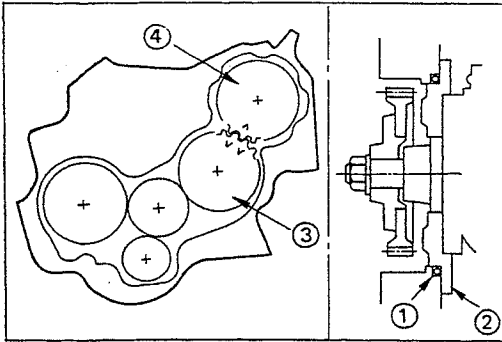

▲ Injection Pump (For Gear Drive)

- 1) Install the O-ring ① to the injection pump flange ②.
- 2) Install the injection pump to the timing gear case. Align the idler gear "B" ③ "V-V" mark with the injection pump timing gear ④ "V" mark.

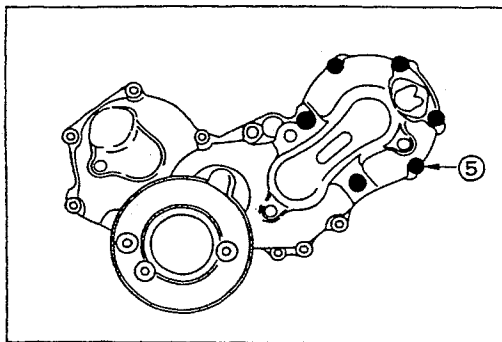

- 3) Temporarily tighten the six injection pump nuts ⑤. The injection pump nuts will be finally tightened after the injection pump rear bracket bolts.

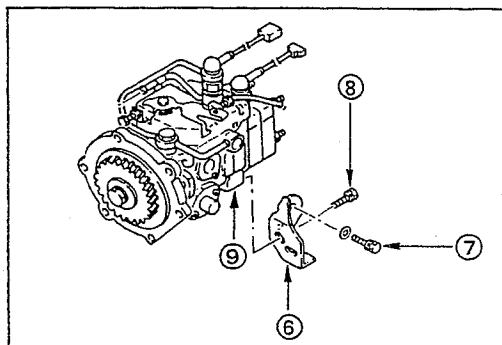

- 4) Install the injection pump rear bracket ⑥ and the rear bracket bolts ⑦ to the cylinder body.
- 5) Install the rear bracket bolts ⑧ to the injection pump bracket ⑨. Do not tighten the bolts. The rear bracket bolts ⑦ and ⑧ will be finally tightened to the specified torque after the injection pump nuts.

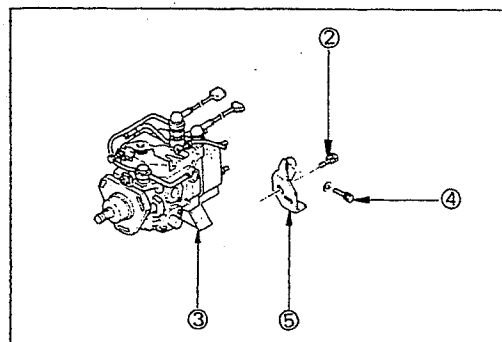

- 6) Tighten the injection pump nuts to the specified torque.

Injection Pump Nut Torque	kg·m(lb.ft/N·m)
	$1.5 \pm 0.5 (10.8 \pm 3.6/14.70 \pm 4.90)$

- 7) Tighten the injection pump bracket bolts to the specified torque.

Injection Pump Bracket Bolt Torque	kg·m(lb.ft/N·m)
	$1.5 \pm 0.5 (10.8 \pm 3.6/14.70 \pm 4.90)$

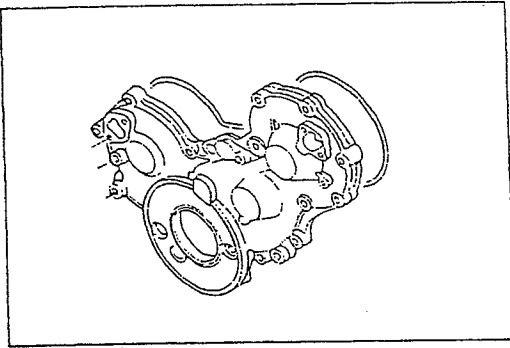

▲ Timing Gear Case Cover (For Gear Drive)

- 1) Align the gear case with the timing gear case knock pin and then install the timing gear case cover.
- 2) Tighten the gear case cover bolts to the specified torque.

Gear Case cover Bolt Torque	kg·m(lb.ft/N·m)
	1.9 ± 0.5 ($13.7 \pm 3.6/18.62 \pm 4.90$)

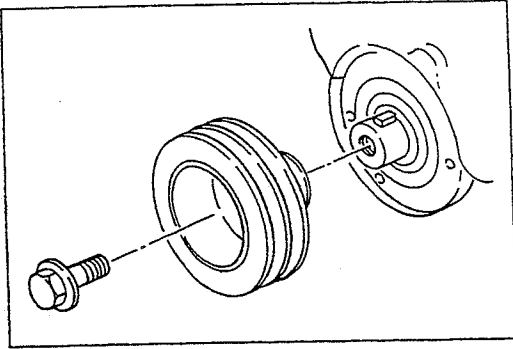

▲ Crankshaft Damper Pulley (For Gear Drive)

Tighten the crankshaft damper pulley bolt to the specified torque.

Note:

Hold the flywheel ring gear stationary to prevent the crankshaft from turning when tightening the damper pulley.

Crankshaft Damper Pulley Bolt Torque	kg·m(lb.ft/N·m)
	19.0 ± 1.9 ($137.4 \pm 13.7/186.20 \pm 18.62$)

Take care not to damage the crankshaft damper pulley boss.

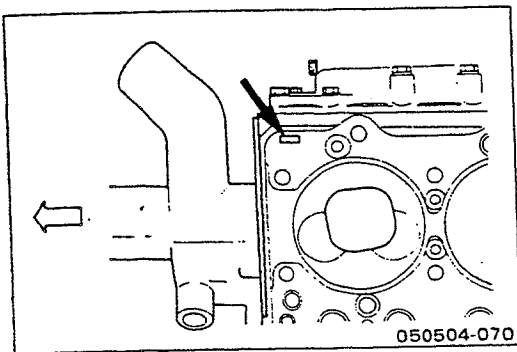

▲ Cylinder Head Gasket

The cylinder head gasket "TOP" mark must be facing up.



Note:

For all 4JB1 engines, measure the piston head projection and select the appropriate head gasket.

Refer to "INSPECTION AND REPAIR", "Cylinder Head Gasket Selection".



▲ Cylinder Head

- 1) Align the cylinder body dowels and the cylinder head dowel holes.
- 2) Carefully place the cylinder head on the cylinder head gasket.
- 3) Apply a coat of engine oil to the cylinder head bolts and setting faces.



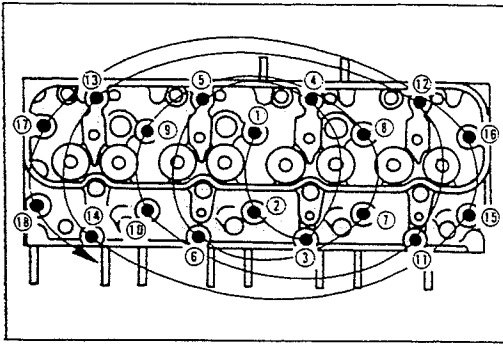

- Tighten the cylinder head bolts in two steps using the Angular Tightening Method for all 4JB1. Follow the numerical sequence shown in the illustration.

Cylinder Head Bolt Torque		kg ·m(lb.ft/N ·m)
		1st Step
All 4JB1		5.0 ± 0.5 ($36.2 \pm 3.6/49.00 \pm 4.90$)
		2nd Step
		$120^\circ + 30^\circ$ $- 0^\circ$

Cylinder Head Bolt Torque		kg ·m(lb.ft/N ·m)
4JA1	New bolt	8.7 ± 0.5 ($62.9 \pm 3.6/85.26 \pm 4.90$)
	Used bolt	10.5 ± 0.5 ($75.9 \pm 3.6/102.90 \pm 4.90$)

0505040119

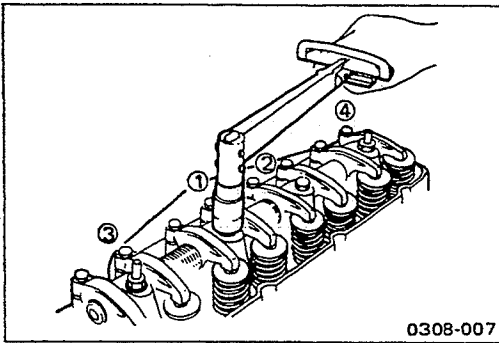

▲ Rocker Arm Shaft and Rocker Arm

- Tighten the rocker arm shaft bracket bolts in the numerical order shown in the illustration.

Rocker Arm Shaft Bracket Bolt Torque		kg·m(lb.ft/N·m)
		5.5 ± 0.5 ($37.8 \pm 3.6/53.96 \pm 4.90$)

0505040125

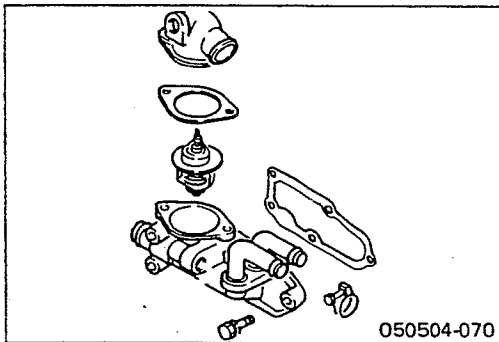

▲ Thermostat Housing

- Install the thermostat housing.
- Tighten the thermostat housing bolts to the specified torque.

Thermostat Housing Bolt Torque		kg·m(lb.ft/N·m)
		1.9 ± 0.5 ($13.7 \pm 3.6/18.64 \pm 4.90$)

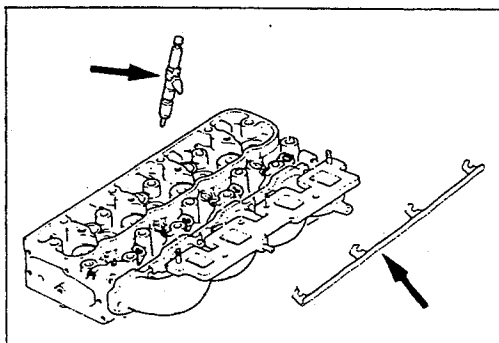

▲ Glow Plug and Glow Plug Connector

- Install the glow plugs to the cylinder head.
- Tighten the glow plugs to the specified torque.

Glow Plug Torque		kg·m(lb.ft/N·m)
		2.25 ± 0.25 ($16.3 \pm 1.8/22.07 \pm 2.45$)

- Install the glow plug connector.
- Tighten the glow plug connector to the specified torque.

Glow Plug Connector Torque		kg·m(lb.ft/N·m)
		0.13 ± 0.2 ($0.94 \pm 1.4/1.27 \pm 1.96$)

Note:

Glow plugs in good condition may be reused.

If glow plug replacement is required, the glow plugs must be replaced as a set. Never replace just one glow plug.

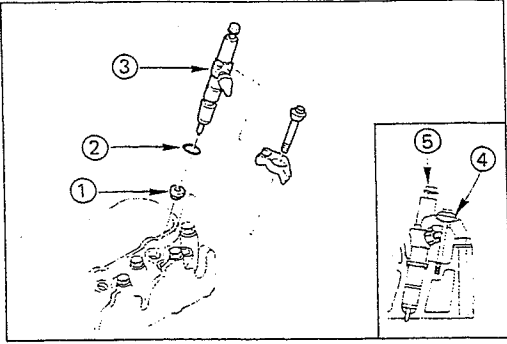

▲ Injection Nozzle Holder

- 1) Install the injection nozzle gasket ① and the O-ring ② to the injection nozzle holder ③.
Be sure that the O-ring fits snugly in the injection nozzle groove.
- 2) Apply engine oil to the cylinder head nozzle holder hole.
- 3) Install the nozzle holder together with the nozzle holder bracket ④ to the cylinder head.

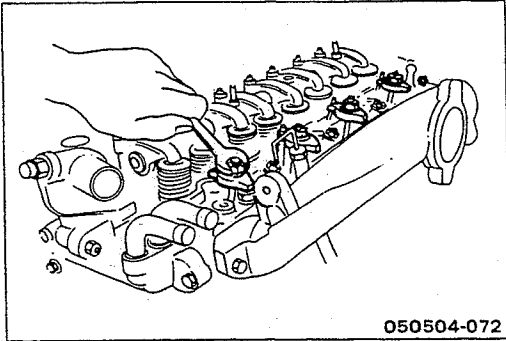

Nozzle Holder Bracket Bolt Torque kg-m(lb.ft/N-m)
 $3.8 \pm 0.6 (27.5 \pm 4.3/37.24 \pm 5.88)$

- 4) Tighten the holder nut with washer ⑤ to the specified torque.

Injection Nozzle Holder Nut Torque kg-m(lb.ft/N-m)
 $3.8 \pm 0.6 (26.0 \pm 4.3/37.24 \pm 5.88)$

0505040131

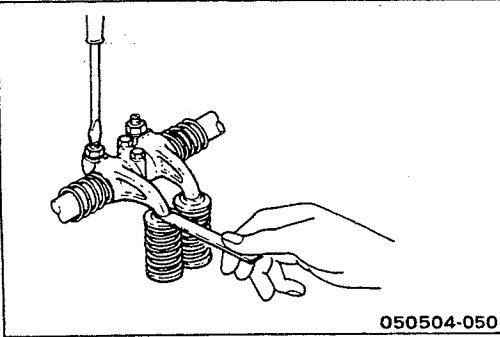

Note on Valve Clearance Adjustment

Valve clearances must be adjusted before the cylinder head cover is reinstalled.

Refer to "Valve Clearance Adjustment" in the "Servicing" Section of this Manual.

050504-050

050504013201

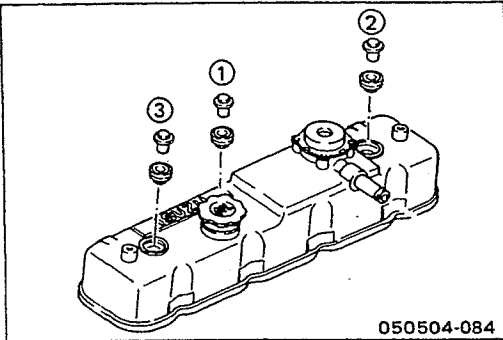

▲ Cylinder Head Cover



- 1) Apply engine oil to the rocker arm and the valve spring.
- 2) Install the cylinder head cover gasket to the head cover.

Check to see that the head cover gasket has no loose areas.

- 3) Tighten the cylinder head cover nuts in the numerical order shown in the illustration.

Cylinder Head Cover Bolt Torque kg-m(lb.ft/N-m)
 $1.3 \pm 0.5 (9.4 \pm 3.6/12.74 \pm 4.90)$